

Dimensions

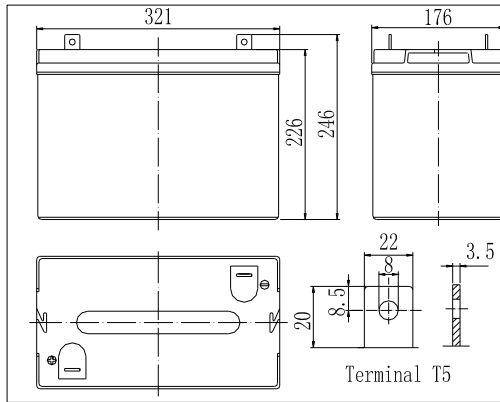

The Relationship for Open Circuit Voltage and Residual Capacity (25°C)

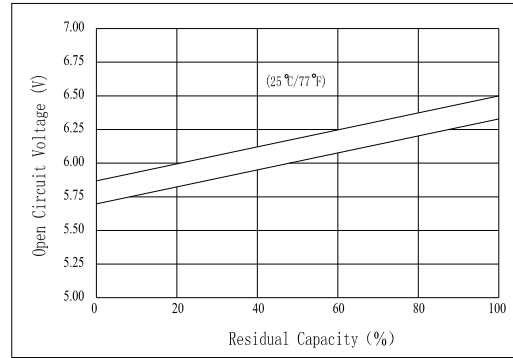

Specifications

Nominal Voltage		6 V
Capacity(10HR, 25°C)		200 Ah
Dimension	Length	321mm (12.64inch)
	Width	176mm (6.93inch)
	Height	226mm (8.90inch)
	Total Height	246mm (9.69inch)
Approx. Weight		32kg (70.6lbs)
Internal resistance (Fully charged, 25°C)		Approx. 3.1mΩ
Capacity affected by temperature (10HR)	40°C	102%
	25°C	100%
	0°C	85%
	-15°C	65%
Self-discharge (25°C)	3 month	Remaining Capacity: 91%
	6 month	Remaining Capacity: 82%
	12 month	Remaining Capacity: 65%
Nominal operating temperature		25°C ±3°C (77°F ±5°F)
Operating temperature range		-15°C ~50°C (5°F ~122°F)
Float charging voltage(25°C)		6.75 to 6.90V
Cyclic charging voltage(25°C)		7.25 to 7.45V
Maximum charging current		60A
Terminal material		Copper
Maximum discharge current		1600A(5 sec.)

Charging Characteristics(25°C)

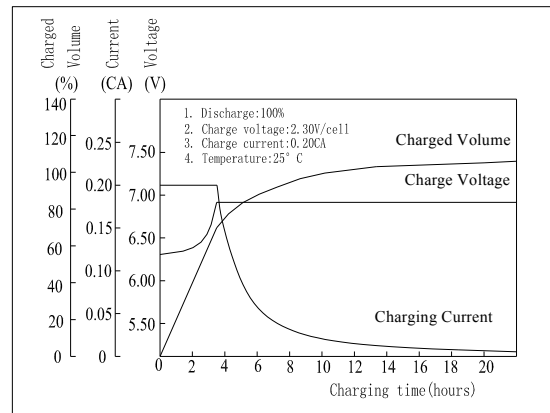

Cycle Life(25°C)

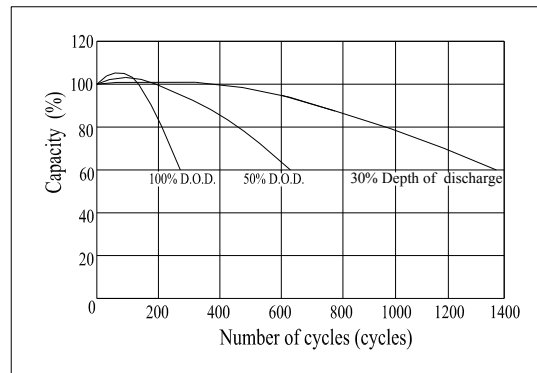

Note: Floating life at 20°C designed for 7 to 10 years

- ◆ Absorbent glass mat technology;
- ◆ Recognized by UL & CE;
- ◆ ABS container.

Constant Current Discharge Characteristics (A, 25°C)

F.V/TIME	5min	10min	15min	30min	60min	3h	5h	10h	20h
4.80V	643	428	333	210	127	51.8	36.5	20.3	10.7
5.10V	610	407	320	202	122	51.0	36.0	20.1	10.6
5.40V	574	383	304	192	116	50.0	35.3	20.0	10.5

Constant Power Discharge Characteristics (Watt, 25°C)

F.V/TIME	5min	10min	15min	30min	60min	3h	5h	10h	20h
4.80V	3374	2313	1830	1179	725	304	216	121	63.9
5.10V	3205	2198	1757	1131	696	300	213	120	63.4
5.40V	3013	2066	1669	1075	662	294	209	120	63.0